

Waste King®

C O M M E R C I A L

by Anaheim Manufacturing

1000-1
1 HP ■ Single Phase
1000-3
1 HP ■ 3 Phase

COMMERCIAL FOOD WASTE DISPOSER SPECIFICATIONS

APPLICATION *SCHOOL CAFETERIAS, HOSPITALS, CLINICS,
SMALL TO MEDIUM SIZE RESTAURANTS WITH SOME
DIFFICULT FOOD WASTE. WHERE VOLUME IS MEDIUM TO HEAVY.*

WASTE KING® EXCLUSIVES

- Stainless Steel Swivel Impellers swivel and retract if they are jammed so that they return to the grinding position during revolution, reducing motor overloading and costly jams. Waste King's stainless steel swivel impellers eliminate the need for reversing switches and special "de-jamming" wrenches.
- Stainless Steel Undercutter Blade located beneath the grind ring snips fibrous and stringy waste into small particles making them less likely to clog drain lines.
- Hush-Cushions® isolate the unit from metal to metal contact, significantly reducing noise level. Hush-Cushions® are specially compounded and designed to withstand vibration and tension, and have a built-in safety splash guard.



FEATURES

- 1 HP disposer, dual voltage
- Fan cooled motor with ball bearing construction and integral overload protection
- Dynamically balanced for smooth, long wearing operation
- Hush Cushion® mounting connection for 6" cone or sink opening includes an auxiliary water inlet
- Stainless steel grind chamber
- Corrosion proof, glass reinforced polyester exit chamber
- 6 1/4" Diameter stainless steel turntable
- Ripper bar integrated with turntable
- 2 Jam resistant, hardened stainless steel swivel impellers
- 3 Stainless steel undercutter blades
- Hard, tough, cast alloy grind ring with dual stage grinding action
- Lifetime particle size control by non-wearing exit slots

MOUNTING SYSTEMS

Sink Mount Assembly (SM)

- #2539 3 1/2" Bolt-in adapter for suspended models with 6" throat

Trough Mount Assembly (TM)

- #2536 6" Weld-in flange for models with 6" throat

Basic Cone Assembly (B)

- 12", 15", or 18" Cone with Swirl Sprays

All-Purpose Cone Assembly (AP)

- 12", 15", or 18" Cone with Swirl Sprays
- Silver Guard
- Scrap Ring

Dish Table Cone Assembly (DT)

- 12", 15", or 18" Cone with Swirl Sprays
- 12", 15", or 18" Cone Cover
- Scrap Ring

Add desired Waste King water controls, switch or panel control box to complete your package. (See catalog)

PLUMBING Models 1000-1 and 1000-3 are equipped with a drain outlet for connection to a conventional 1½" trap. The trap may be connected to a 2" branch waste line running directly into a waste stack. We recommend a slope in the waste line of not less than ¼" per foot. Connect directly to waste line, not through a grease interceptor.

MOTOR DATA

- | | |
|-------------------------|---------------------|
| 1000-1 | 1000-3 |
| ▪ 60 cycle | ▪ 60 cycle |
| ▪ 1 Phase | ▪ 3 Phase |
| ▪ 1 HP | ▪ 1 HP |
| ▪ 1725 RPM | ▪ 1725 RPM |
| ▪ 110-120/220-240 volts | ▪ 208-240/460 volts |
| ▪ 12.0/6.0 amps | ▪ 3.2/1.6 amps |
- Bearing permanently lubricated.
Manual reset overload protection in motor.

TO SPECIFIERS So that you may be assured of receiving the fine quality you expect when you specify a WASTE KING® FOOD WASTE REMOVAL SYSTEM, we include the following sample specification for your convenience:

- Food waste disposer shall be 1 HP, 60 cycle, 1 Phase with 110-120/220-240 volts or 3 Phase with 208-240/460 volts.
- There shall be a rubber Hush Cushion® between the disposer and the cone or sink to eliminate metal to metal contact.
- Turntable shall be of stainless steel with jam-resistant swivel impellers of stainless steel and stainless steel cutting blade rotating below the exit slots.
- Grind ring shall be precision ground on all cutting surfaces and shall have non-wearing, size controlled exit slots.
- Disposer shall have a totally enclosed, continuous duty, fan cooled motor with integral overload protection.
- Unit shall be Waste King® model 1000-1 or 1000-3.

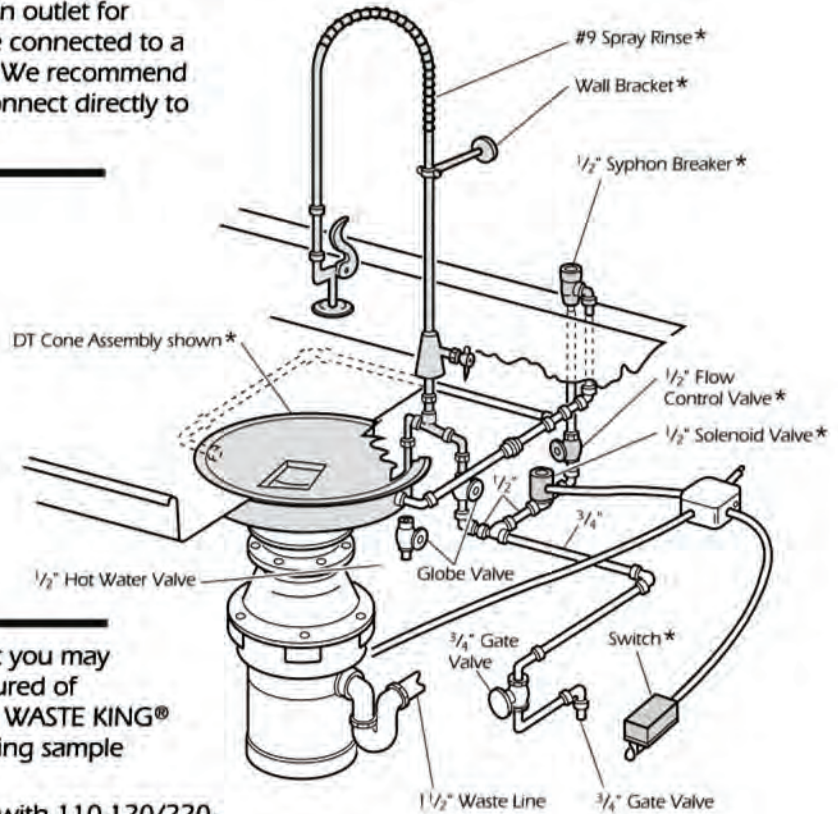

NOTE:

1. Disposer assembly includes disposer, mountings, and drain outlet. Other items shown in gray are available in mounting systems or ordered separately.
2. Installation should be made in accordance with local codes.
4. All specifications subject to change without notice.
3. Assembly should be installed in accordance with Waste King's printed installation instructions.

* Items available through Waste King

ROUGH-IN DIMENSIONS WITH DRAIN LINE CONNECTIONS

Cone Mounted Models

	1000-1		1000-3	
	IN	CM	IN	CM
A	25 ⁵ / ₈	65.1	25 ¹ / ₈	63.7
B	6 ⁵ / ₈	16.8	6 ⁵ / ₈	16.8
C	19	48.2	18 ⁷ / ₁₆	46.8
D	6	15.2	6	15.2
E	2 ¹ / ₈	5.4	2 ¹ / ₈	5.4
F	8	20.3	8	20.3
G	9	22.7	9	22.7
H	7 ³ / ₄	19.7	7 ³ / ₄	19.7

Slope = ¼"p/ft.

Sink Mounted Models with #2539 Sink Mount Installation

Special Order ONLY

	1000-1 with #2539 Sink Mount Installation		1000-3 with #2539 Sink Mount Installation	
	IN	CM	IN	CM
A	19 ¹ / ₂	49.5	19	48.2
B	9	22.7	9	22.7
C	8 ¹ / ₂	21.6	8 ¹ / ₂	21.6
D	3 ¹ / ₂	8.9	3 ¹ / ₂	8.9
E	2 ³ / ₈	5.9	2 ³ / ₈	5.9
F	7 ³ / ₄	19.7	7 ³ / ₄	19.7

Slope = ¼"p/ft.