

# Specifications

## Disposal Description

- EZ Mount twist-and-lock sink flange for fast and easy installation
- 1 HP permanent magnet motor delivers 2800 rpms of grinding power and reduces jams
- Lined with insulation to reduce sound
- Pre-installed power cord for easy plug-in install, no hardwiring or separate purchase required
- Stainless steel grinding components
- Reinforced polymer grind chamber resists corrosion and extends disposal life
- Batch feed disposal is activated by the drain cover, providing a safer grind
- Compact, lightweight design saves space
- Safe to use with properly sized septic tanks
- Front-mounted reset button

## Included Components

- Waste King L-8000TC EZ Mount Disposal Unit
- Pre-installed power cord
- Celcon sink flange and plastic drain stopper/disposal actuator
- Drain elbow and EZ-Mount mounting assembly

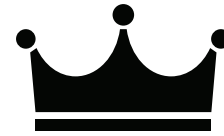

## WASTE KING Model L-8000TC



### Critical Dimensions

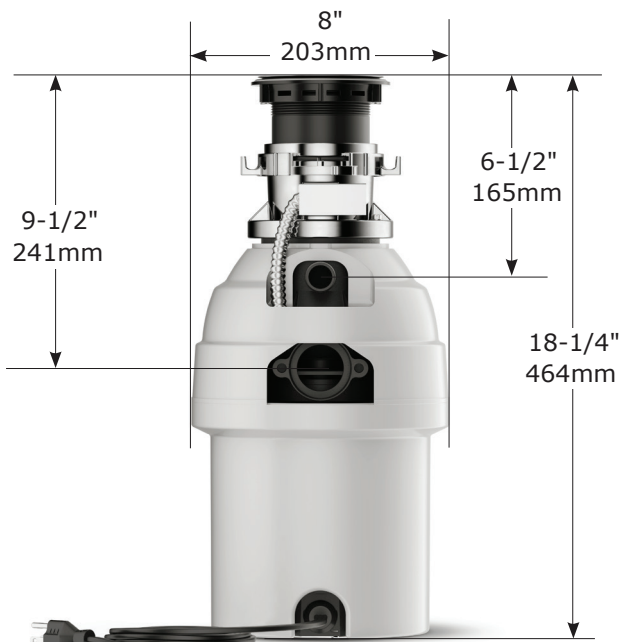

Weight 13.4 lbs.

**Ten Year Limited Warranty**  
If the disposal develops a material or mechanical defect during the warranty period, Waste King will replace it free of charge.

| Specification Detail              |                                       |
|-----------------------------------|---------------------------------------|
| Motor Horsepower                  | 1 H.P.                                |
| R.P.M.                            | 2800                                  |
| Mount                             | EZ Mount                              |
| Sound Insulation                  | Yes                                   |
| Warranty                          | Ten Year Limited                      |
| Voltage,HZ                        | 115, 60                               |
| Current-Amps                      | 7.0                                   |
| Power Cord                        | Pre-Installed                         |
| Motor Type                        | Permanent Magnet                      |
| On/Off Control                    | Stopper Controlled                    |
| Drain Connection Size             | 1-1/2 inch drainpipe                  |
| Dishwasher Compatibility          | 7/8 inch rubber dishwasher drain hose |
| Maximum Sink Thickness            | 1/2 inch                              |
| Sink Flange Material              | Celcon                                |
| Sink Flange Finish                | Stainless Steel                       |
| Splash Guard                      | No                                    |
| Feed                              | Batch                                 |
| Internal Grind Component Material | Stainless Steel                       |
| Grind Chamber Material            | Reinforced Polymer                    |
| Overload Protector                | Manual Reset Type                     |

FOR MORE INFORMATION CALL: **1-800-854-3229**  
**WasteKing.com**